

Disassembly Instructions, H-10/H-11

Rev.	A	Date:	2018-01-17	Author	TZ
Notice	<ul style="list-style-type: none"> ● There are variants of this module, causing minor individual weight difference. ● Parts containing plastic and steel should be separated. Printed circuit boards should be separated from steel. 				
Suggested tools	<ul style="list-style-type: none"> ● Socket wrenches 7, 8, 17 mm ● Torx screwdrivers T20, T30 ● Hex key 2, 5 mm ● Cross head screwdrivers M3 ● Circlip plier ● Cutting pliers, medium 				
Part number(s)	90922001 90926001 90942001 90946001 90962001 90966001	Name	H-10 CHN H-11 CHN H-10 EXPORT H-11 EXPORT H-10 TOMRA H-11 TOMRA		

H-10 overview

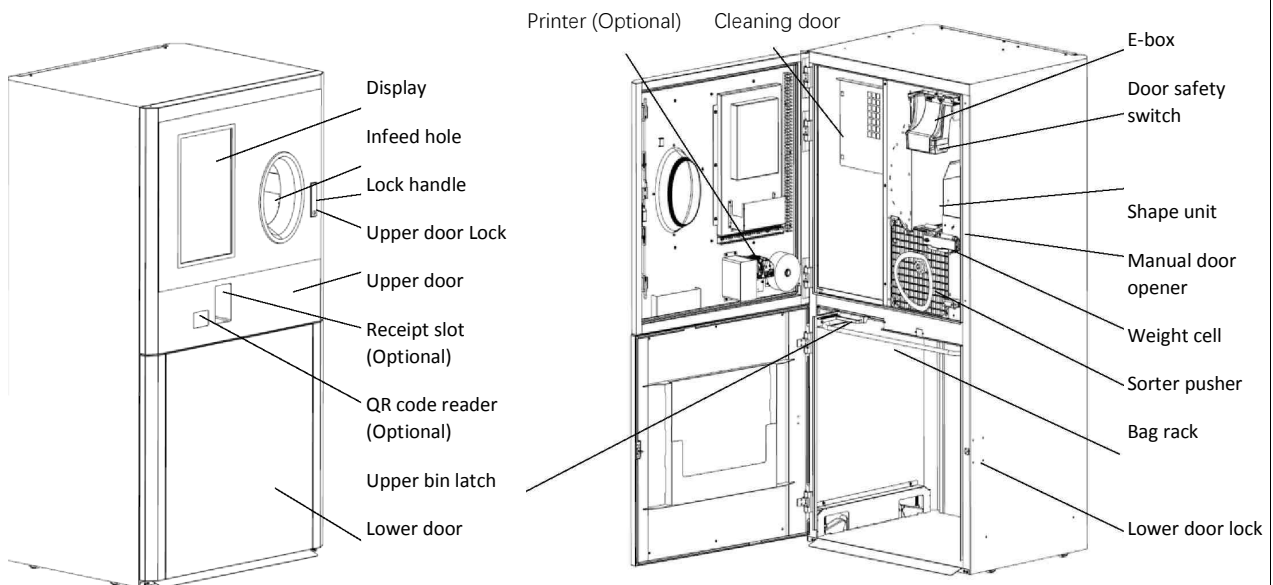

Note:

Printer, QR code reader are optional parts, they may not present at RVM

H-11 overview

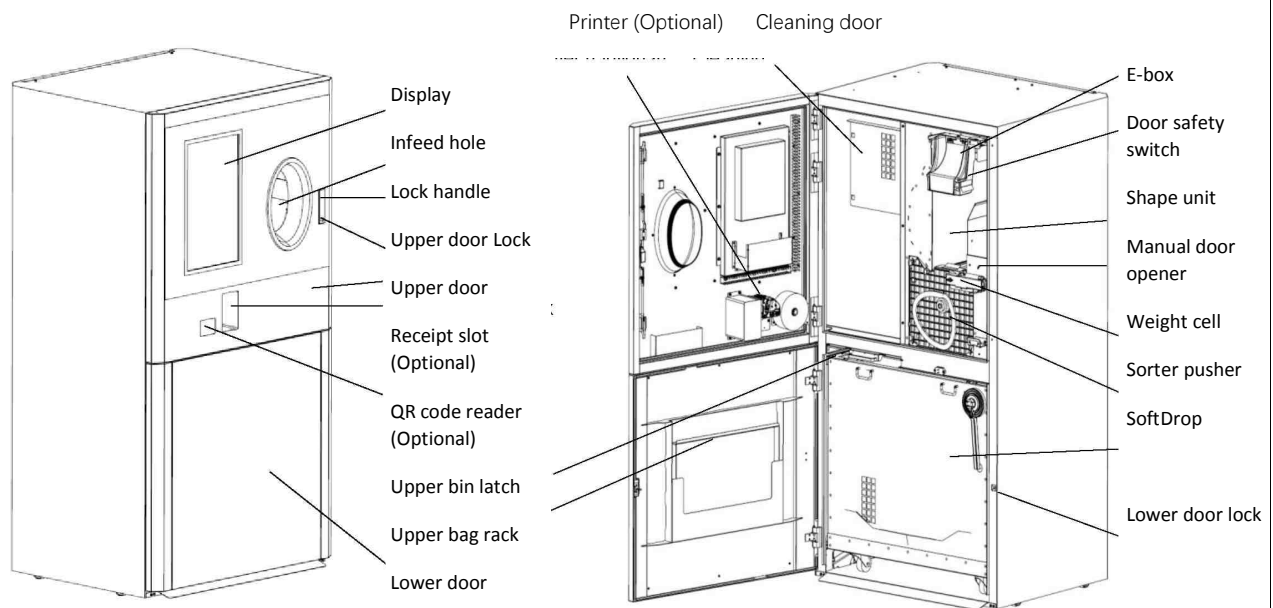

Note:

Printer, QR code reader are optional parts, they may not present at RVM.

Material type and weight	Steel and Iron	210 Kg. (H-10) 244.5 Kg. (H-11)	Plastic	4 Kg. (H-10) 4.5 Kg. (H-11)	Other	Kg.
	Aluminum	1 Kg. (H-10) 2.5 Kg. (H-11)	Rubber	0.1 Kg.	Other	Kg.
	EEE parts	10 Kg. (H-10) 13.5 Kg. (H-11)	Float glass	5 Kg.	Other	Kg.
Dismantling procedure	70922200 H-10/H-11 Service Manual					
Suggested dismantling procedure						
Step	Part	Material				
1	Remove all covers and doors	Steel				
2	Remove sorter, SoftDrop (H-11) and their drive units	Steel, Alu, Plastic, EEE parts (motors, cables)				
3	Remove internal components: E-box, door locks, shape unit, weight module, printer module, IPC, QR code reader module, power box, wheels, photocell and reflector	Steel, Plastic, EEE parts				
4	Remove cables	Cable (EEE)				
5	Dismantle framework	Steel				
6	Dismantle assembled units: <ul style="list-style-type: none"> • Power box • Shape unit • Weight module • Printer module • Sorter • Sorter drive unit • SoftDrop • SoftDrop drive unit • E-box • IPC • QR code reader module 	Steel, Alu, Plastic, EEE parts (PCB, motors, cables)				